

# Flo-Tite, Inc.

## Valves & Controls

### 3 - WAY BRASS - Multi - Port Series

- T- Port & Diverter Type Ball Valves
- Threaded Ends
- Standard Port
- 1/4" thru 3"

#### MODELS

- T- Port MPT 355
- L- Port MPT 365

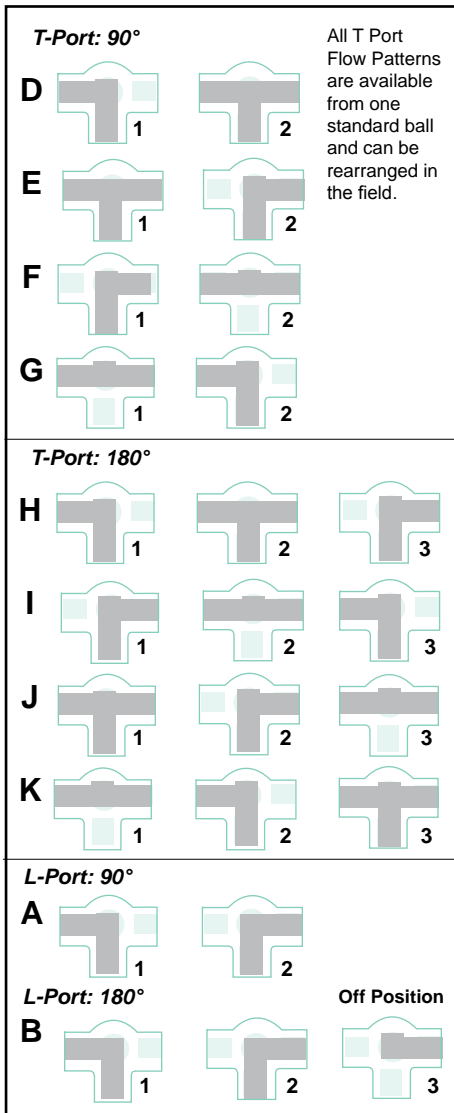

### UNIQUE DESIGN FEATURES

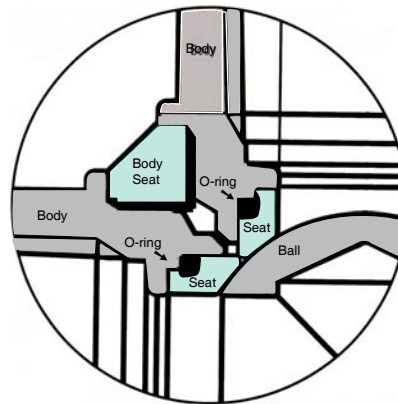

Standard Seat Design is live loaded using O - Rings Provides Longer life with Reduced Torques

- Four Seat Design in both T & Diverter Types allows for an off Position
- Pressure Rating: 400 WOG/100 WSP
- PTFE Double O - Ring Stem Seal
- Actuator Mounting Pad complies to ISO 5211 bolting pattern
- Forged Brass Body

#### 3 WAY VALVES

REDUCE THE NUMBER OF VALVES IN PIPING SYSTEMS AND INCREASE EFFICIENCY

**DESIGN & TECHNICAL DATA**

**3 WAY FORGED BRASS THREADED END BALL VALVE**

**BILL OF MATERIALS:**

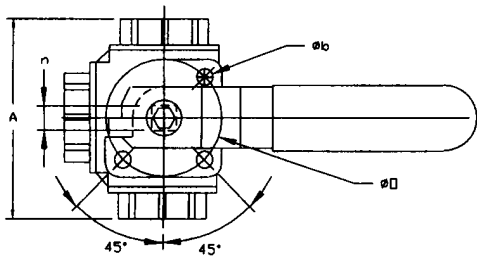
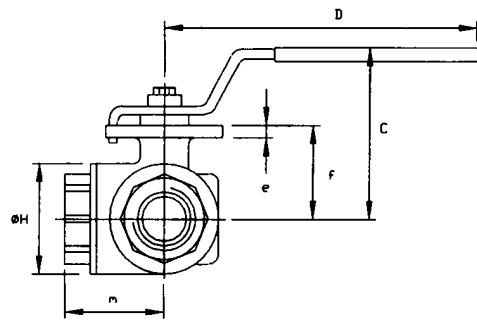
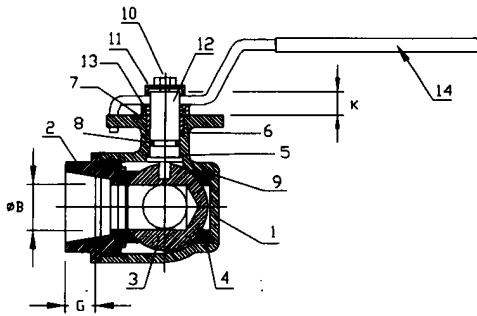

ITEM	NAME	MATERIAL	QTY.
1	BODY	BRASS UNI 5705-65	1
2	END CAP	BRASS UNI 5705-65	3
3	BALL	BRASS UNI 5705-65	1
4	BALL SEAT	VIRGIN PTFE	4
5	THRUST WASHER	VIRGIN PTFE	1
6	STEM SEAL	VIRGIN PTFE	1
7	STEM RETAINING NUT	BRASS UNI 5705-65	1
8	O - RING	FKM (Viton)	1
9	O - RING	FKM (Viton)	4
10	SCREW	PLATED STEEL	1
11	BUSH	BRASS UNI 5705-65	1
12	STEM	BRASS UNI 5705-65	1
13	WASHER	NYLON	1
14	HANDLE	PLATED STEEL	1

**MODELS:** T Port MPT355  
L Port MPT365

**DESIGN TECHNICAL DATA**

- PRESSURE RATING: 400 PSI WOG/100 WSP
- OPERATING TEMPERATURE: -20°F TO 375°F
- BODY TEST: 600 PSI
- SEAT TEST: 80 PSI AIR UNDER WATER FOR BUBBLE TIGHT INTEGRITY
- FOUR SEAT DESIGN
- O - RING LOADED SEATS & STEM SEALS
- BLOW OUT PROOF STEM DESIGN
- ISO 5211 TYPE ACTUATOR MOUNTING PAD IDEAL FOR DIRECT MOUNT ACTUATION

**DIMENSIONS, CV, AND WEIGHTS:**

SIZE	A	B	b	C	D	e	f	G	H	K	m	n	O	CV		Torque #	Weight	Drilling ISO S 24
														MPT365	MPT355	in - ibf	lbs	
1/4"	2.63	0.43	0.236	2.46	4.72	0.19	1.20	0.39	1.33	0.27	1.31	0.35	1.417	3.26	3.50	60.0	1.06	F03
3/8"	2.63	0.43	0.236	2.46	4.72	0.19	1.20	0.40	1.33	0.27	1.31	0.35	1.417	3.50	4.08	60.0	1.20	F03
1/2"	2.87	0.43	0.236	2.46	4.72	0.19	1.20	0.53	1.33	0.27	1.43	0.35	1.417	4.20	5.02	60.0	1.22	F03
3/4"	3.18	0.59	0.236	2.50	4.72	0.19	1.28	0.55	1.59	0.27	1.59	0.35	1.417	7.00	7.70	70.0	1.48	F03
1"	3.74	0.78	0.276	2.95	6.69	0.27	1.63	0.66	1.88	0.43	1.87	0.43	1.969	12.83	14.24	85.0	2.64	F05
1 1/4"	4.38	0.98	0.276	3.12	6.69	0.27	1.85	0.68	2.36	0.43	2.20	0.43	1.969	18.67	19.72	150.0	4.16	F05
1 1/2"	4.86	1.25	0.276	3.66	6.69	0.27	2.34	0.68	2.83	0.43	2.43	0.43	1.969	29.75	30.69	290.0	6.06	F06
2"	5.72	1.57	0.354	4.46	9.05	0.31	2.90	0.69	3.38	0.59	2.86	0.55	2.756	43.76	44.58	370.0	10.40	F07

2 1/2" & 3" Consult Factory For Dimensional Information